



SLIDING AUTOMATIC ENTRANCES: DURA-GLIDE™ 2000, BI-PARTING

1.01 - BI-PARTING WITH TRANSOM

- **1.01.01 - Bi-Parting**
- **1.01.02 - Bi-Parting with Transom**
- **1.01.03 - Bi-Parting with Access Control, Surface Applied**
- **1.01.04 - Bi-Parting with Transom and Access Control, Surface Applied**
- **1.01.05 - Bi-Parting with Access Control, Recessed**
- **1.01.06 - Bi-Parting with Transom and Access Control, Recessed**
- **1.01.07 - Bi-Parting, Surface Applied**
- **1.01.08 - Bi-Parting with Access Control, Recessed, Surface Applied**

BI-PART WITH OPTIONAL TRANSOM	
PROJECT INFORMATION	
PROJECT NAME:	
LOCATION:	
DOOR NUMBER(S):	
DATE:	SHEET: OF

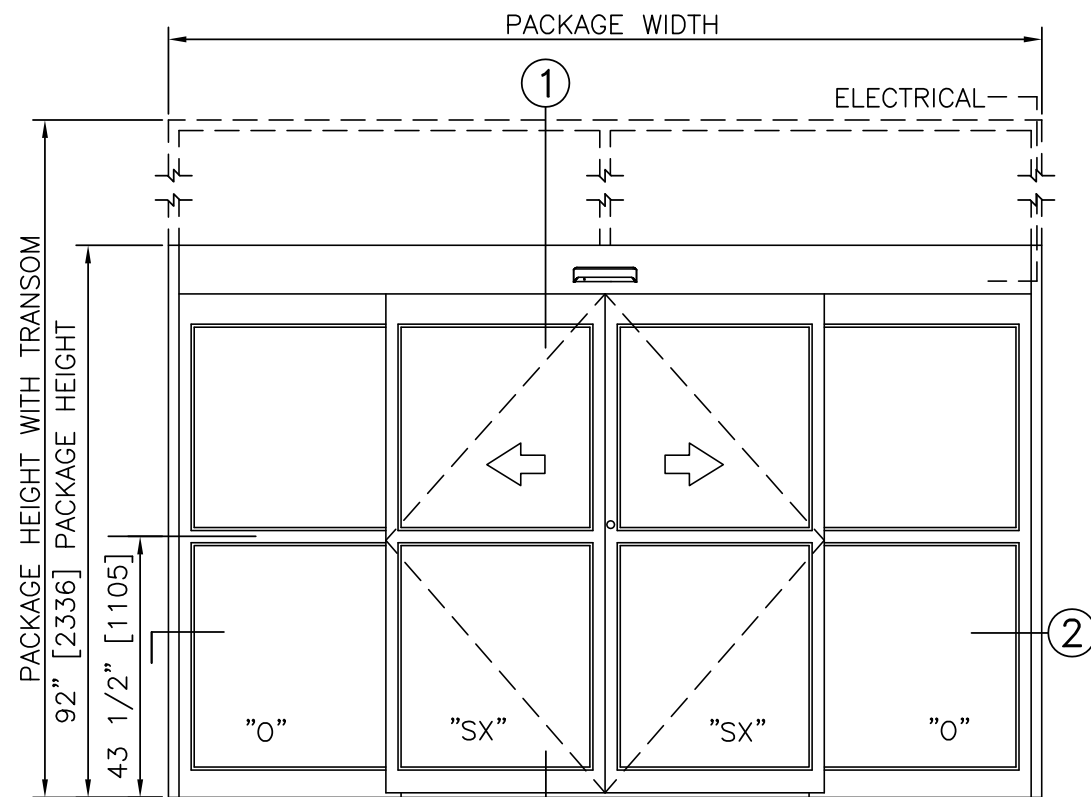

ELEVATION VIEW
SCALE: 3/8" = 1'-0"

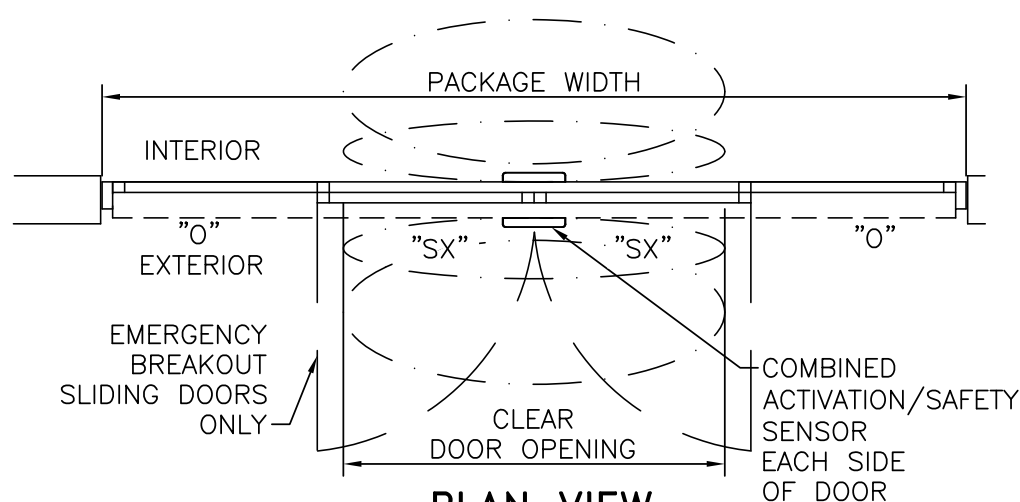

PLAN VIEW
SCALE: 3/8" = 1'-0"

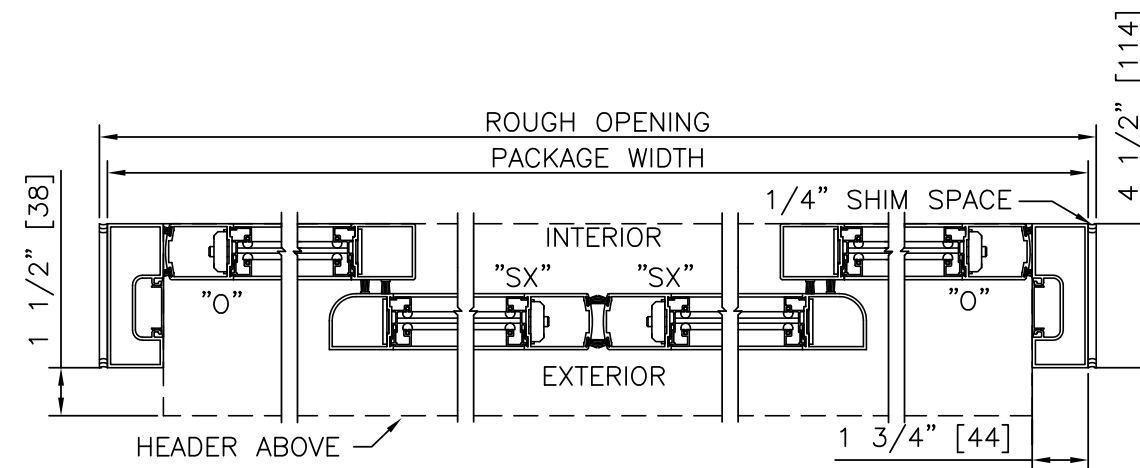

2 HORIZONTAL SECTION
SCALE: 2" = 1'-0"

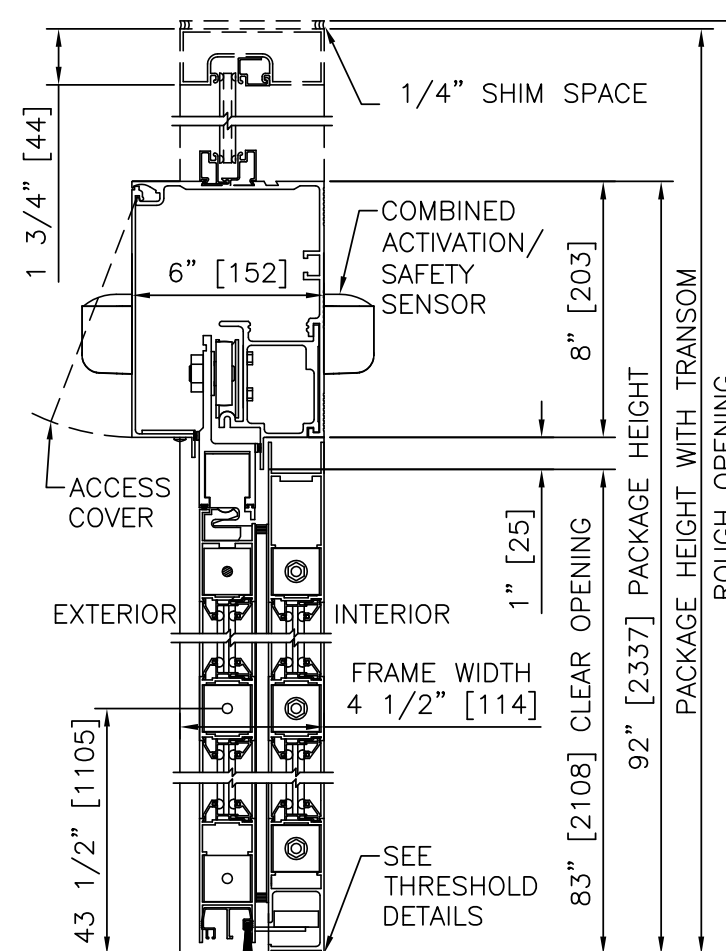

1 VERTICAL SECTION
SCALE: 2" = 1'-0"

PRODUCT OPTIONS

- TRANSOM
- YES
 - VERTICALS 1 2 3
- FINISH
- ANODIZED CLEAR CL2
 - ANODIZED DK BRONZE
 - CUSTOM
- LOCKING
- 2-POINT
 - 3-POINT
 - ACCESS CONTROL (PANIC)
- STILES
- NARROW
 - MEDIUM
- BOTTOM RAILS
- STANDARD 4"
 - OPTIONAL 6" 8" 10" 12"
- THRESHOLDS
- SQ/BVL (EXT)
 - SQ/BVL (INT)
 - DBL BVL
 - RECESSED
- ACTIVATION/SAFETY
- 2 COMBINED ACTIVATION/SAFETY SENSORS
- OTHER OPTIONS
- ROTARY CTRL SWITCH
 - KEYED
 - UNINTERRUPTIBLE POWER SUPPLY
 - FLY OPEN BOX
 - WIND DAMPERS
 - PANEL CLOSERS
 - ALARM CONTACTS
 - CLEAN ROOM (CL 1)

BI-PART FORMULAS - NARROW STILE
 PACKAGE WIDTH = 2 X CLEAR DOOR OPENING + 23.4"
 CLEAR DOOR OPENING = 1/2 PACKAGE WIDTH - 11.7"
 EMERGENCY BREAKOUT WIDTH = CLEAR DOOR OPENING + 7.3"
 DOOR PANEL WIDTH = 1/4 PACKAGE WIDTH + 0.3"

BI-PART FORMULAS - MEDIUM STILE
 PACKAGE WIDTH = 2 X CLEAR DOOR OPENING + 32.1"
 CLEAR DOOR OPENING = 1/2 PACKAGE WIDTH - 16.0"
 EMERGENCY BREAKOUT WIDTH = CLEAR DOOR OPENING + 10.3"
 DOOR PANEL WIDTH = 1/4 PACKAGE WIDTH + 1.1"

PACKAGE WIDTH	NOMINAL CLEAR DOOR OPENING	DOOR PANEL NOMINAL WIDTH	EMERGENCY BREAKOUT NOM. WIDTH
120"	48.3"	30.3"	55.6"
144"	60.3"	36.3"	67.6"
168"	72.3"	42.3"	79.6"

- NOTES**
- ELECTRICAL REQUIREMENTS: 120 VAC, 5 AMP MIN TO POWER OPERATOR BY ELECTRICAL CONTRACTOR.
 - ROUGH OPENING SHALL PROVIDE 1/4"[6] SHIM SPACE ON SIDES AND TOP OF PACKAGE.
 - LIMITS OF ACTIVATION AND SAFETY ZONES ARE FOR REFERENCE ONLY; SEE ANSI/BHMA A156.10 FOR DETAILED REQUIREMENTS.
 - STANDARD LOCKING IS 2-POINT, 3-POINT AND ACCESS CONTROL SYSTEMS AVAILABLE. SEE SHEET 1.60.
 - STANDARD GLAZING STOPS FOR SLIDING AND FIXED PANELS ARE 1/4"[6]; 5/8"[16] AND 1"[25] AVAILABLE.
 - STANDARD JAMB TUBES SHOWN; 6"[152] AVAILABLE.
 - STANDARD STILES, BOTTOM RAILS AND MUNTINS SHOWN; MEDIUM STILES, BOTTOM RAILS TO 12"[305], AND 4 1/4"[108] MUNTINS AVAILABLE.
 - SEE SPECIFICATIONS FOR ADDITIONAL INFORMATION.

**DURA-GLIDE
2000
SERIES**

BI-PARTING

PROJECT INFORMATION

PROJECT NAME:

LOCATION:

DOOR NUMBER(S):

DATE:

SHEET: OF

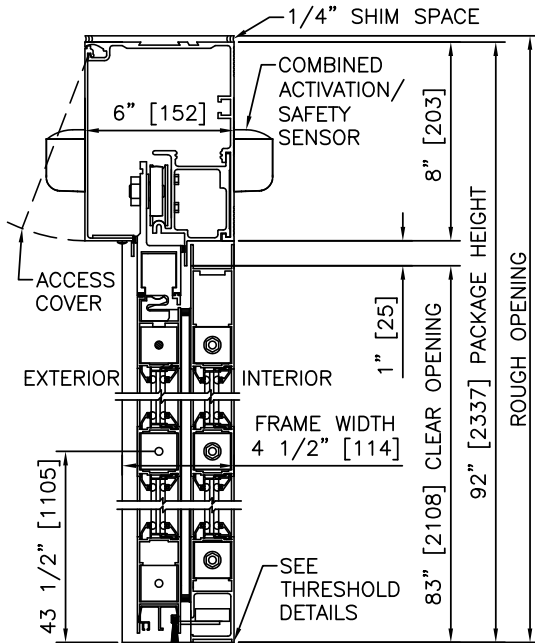

1 VERTICAL SECTION

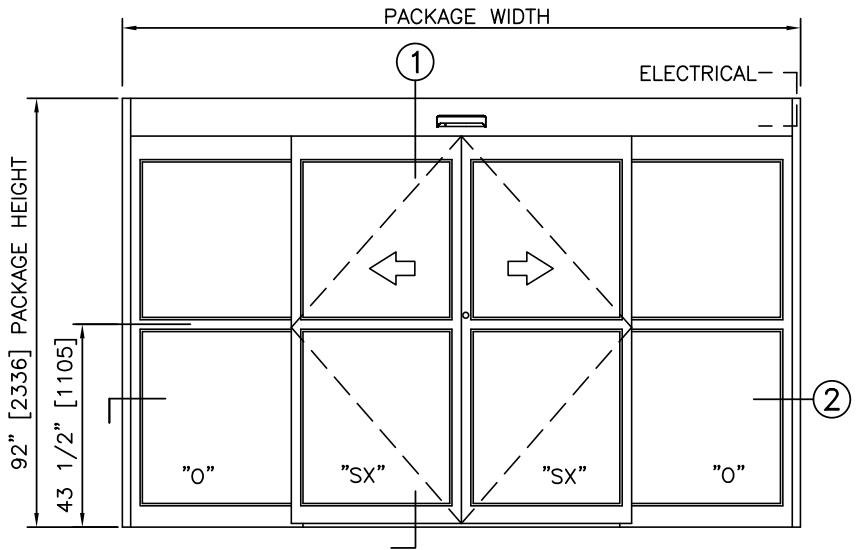

ELEVATION

NOTES

1. ELECTRICAL REQUIREMENTS: 120 VAC, 5 AMP MIN TO POWER OPERATOR BY ELECTRICAL CONTRACTOR.
2. ROUGH OPENING SHALL PROVIDE 1/4"[6] SHIM SPACE ON SIDES AND TOP OF PACKAGE.
3. ACTIVATION AND SAFETY ZONES ARE FOR REFERENCE ONLY; SEE ANSI/BHMA A156.10 FOR DETAILED REQUIREMENTS.
4. SEE SPECIFICATIONS FOR ADDITIONAL INFORMATION.

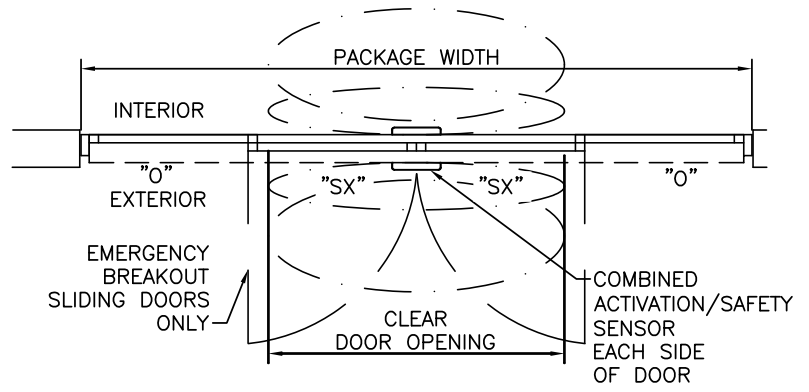

PLAN

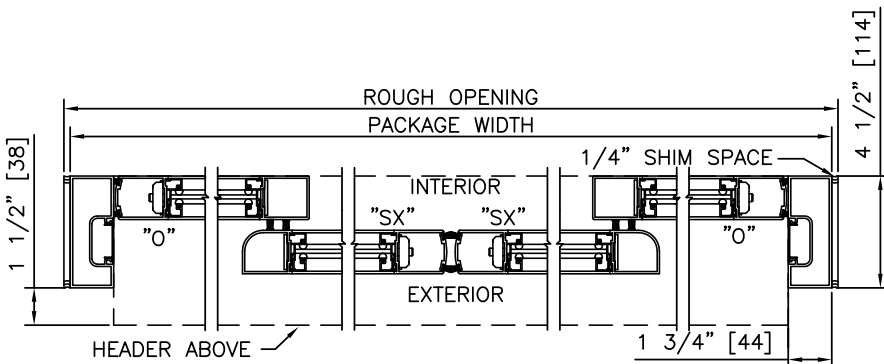

2 HORIZONTAL SECTION

TYPICAL PACKAGE DIMENSIONS (NARROW STILE)

PACKAGE WIDTH	NOMINAL CLEAR DOOR OPENING	DOOR PANEL NOMINAL WIDTH	EMERGENCY BREAKOUT NOM. WIDTH
120"	48.3"	30.3"	55.6"
144"	60.3"	36.3"	67.6"
168"	72.3"	42.3"	79.6"

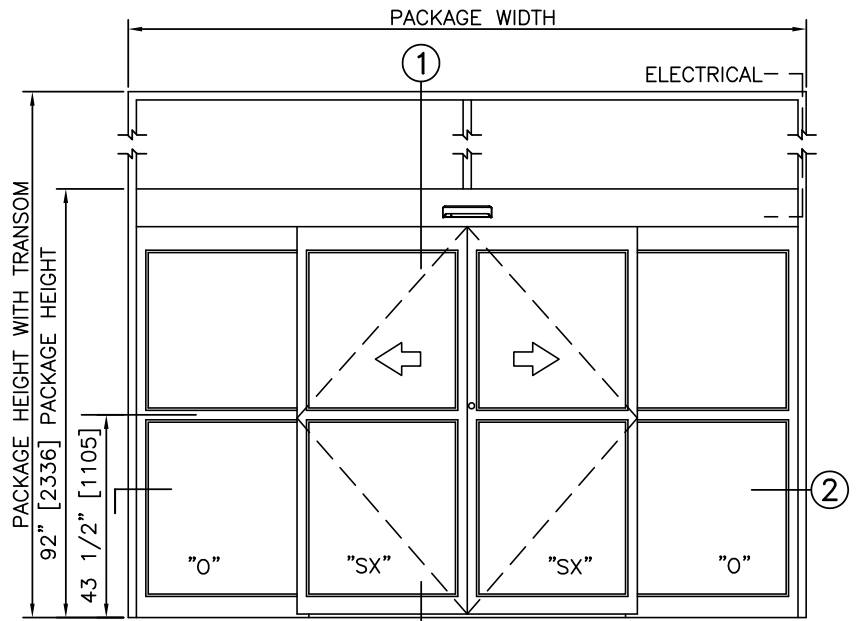
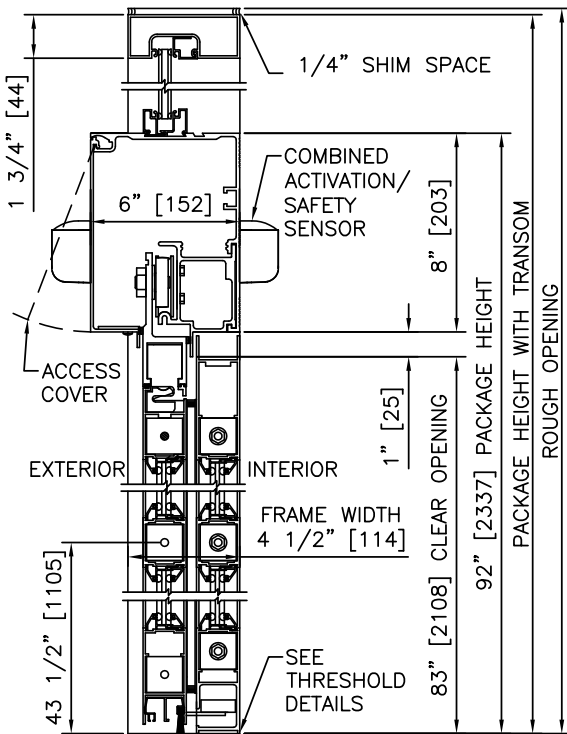

ELEVATION

1 VERTICAL SECTION

NOTES

1. ELECTRICAL REQUIREMENTS: 120 VAC, 5 AMP MIN TO POWER OPERATOR BY ELECTRICAL CONTRACTOR.
2. ROUGH OPENING SHALL PROVIDE 1/4"[6] SHIM SPACE ON SIDES AND TOP OF PACKAGE.
3. ACTIVATION AND SAFETY ZONES ARE FOR REFERENCE ONLY; SEE ANSI/BHMA A156.10 FOR DETAILED REQUIREMENTS.
4. SEE SPECIFICATIONS FOR ADDITIONAL INFORMATION.

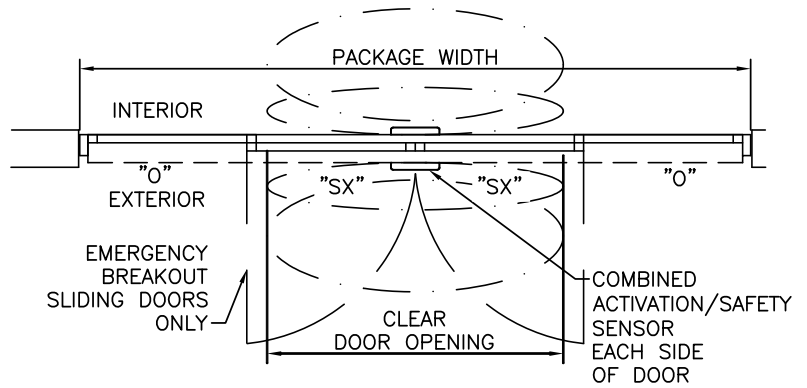

PLAN

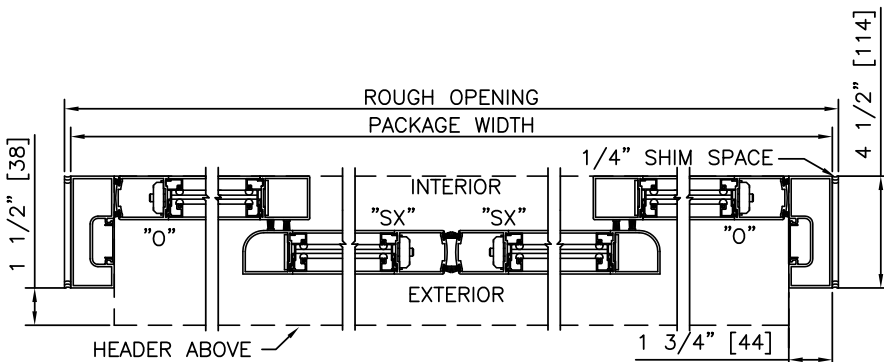

2 HORIZONTAL SECTION

TYPICAL PACKAGE DIMENSIONS (NARROW STILE)

PACKAGE WIDTH	NOMINAL CLEAR DOOR OPENING	DOOR PANEL NOMINAL WIDTH	EMERGENCY BREAKOUT NOM. WIDTH
120"	48.3"	30.3"	55.6"
144"	60.3"	36.3"	67.6"
168"	72.3"	42.3"	79.6"

**DURA-GLIDE
2000
SERIES**

BI-PARTING WITH ACCESS CONTROL, SURFACE

PROJECT INFORMATION

PROJECT NAME:

LOCATION:

DOOR NUMBER(S):

DATE:

SHEET: OF

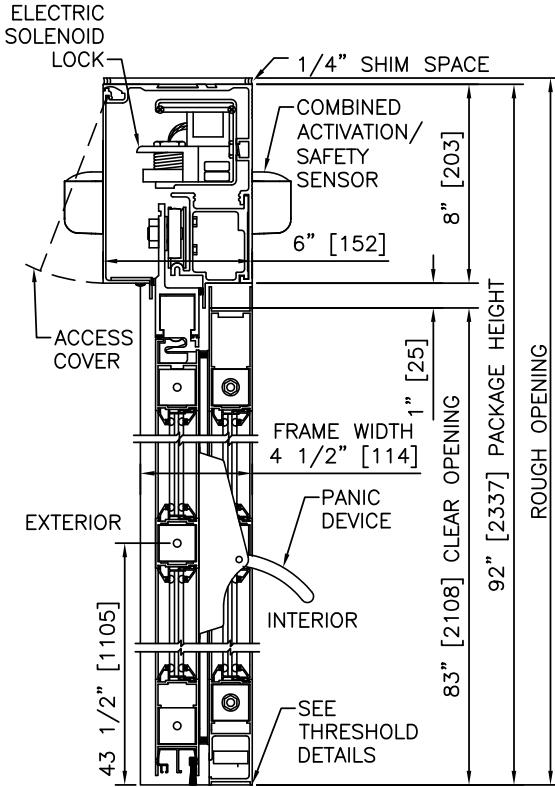

① VERTICAL SECTION

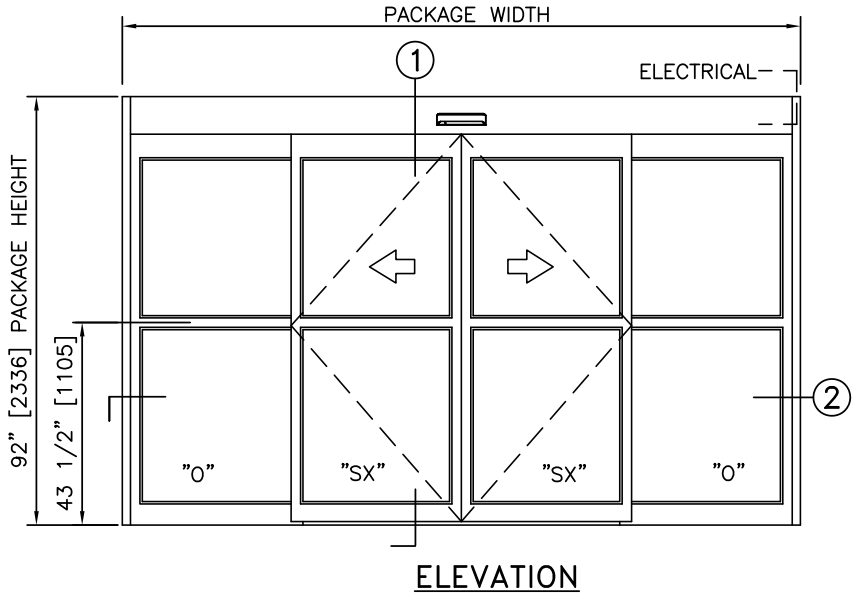

ELEVATION

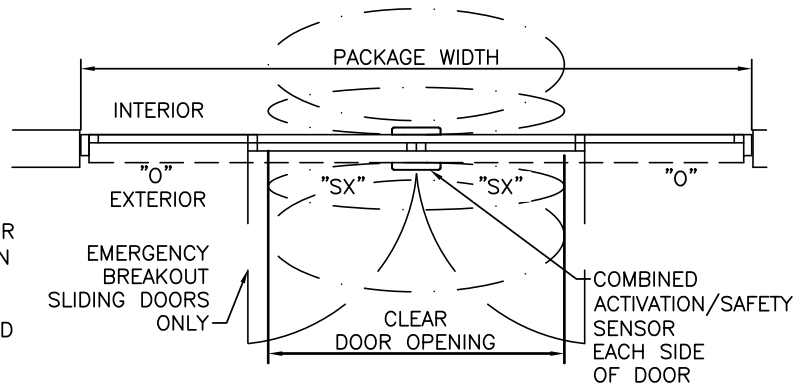

PLAN

NOTES

1. ELECTRICAL REQUIREMENTS: BY ELECTRICAL CONTRACTOR
120 VAC, 5 AMP MIN TO POWER OPERATOR
CONTROL CIRCUIT FROM SECURE ACTIVATION TO OPERATOR
2. ROUGH OPENING SHALL PROVIDE 1/4"[6] SHIM SPACE ON SIDES AND TOP OF PACKAGE.
3. LIMITS OF ACTIVATION AND SAFETY ZONES ARE FOR REFERENCE ONLY; SEE ANSI/BHMA A156.10 FOR DETAILED REQUIREMENTS.
4. SEE SPECIFICATIONS FOR ADDITIONAL INFORMATION.

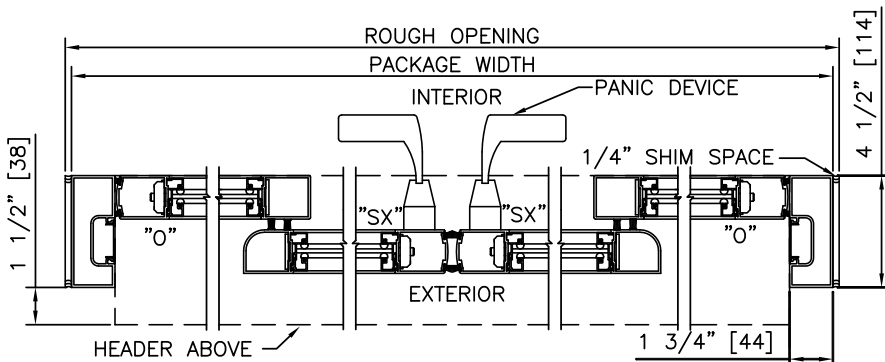

② HORIZONTAL SECTION

TYPICAL PACKAGE DIMENSIONS (NARROW STILE)

PACKAGE WIDTH	NOMINAL CLEAR DOOR OPENING	DOOR PANEL NOMINAL WIDTH	EMERGENCY BREAKOUT NOM. WIDTH
120"	48.3"	30.3"	55.6"
144"	60.3"	36.3"	67.6"
168"	72.3"	42.3"	79.6"

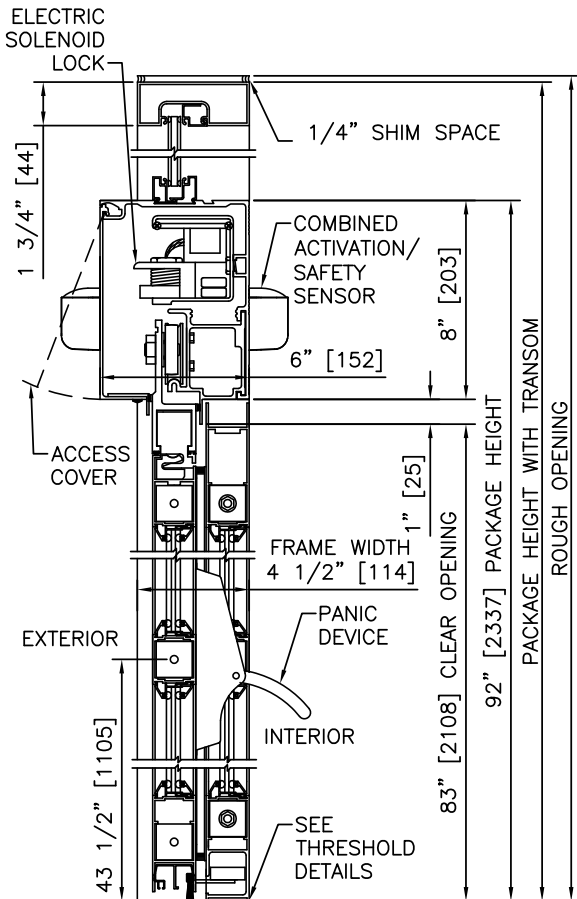

1 VERTICAL SECTION

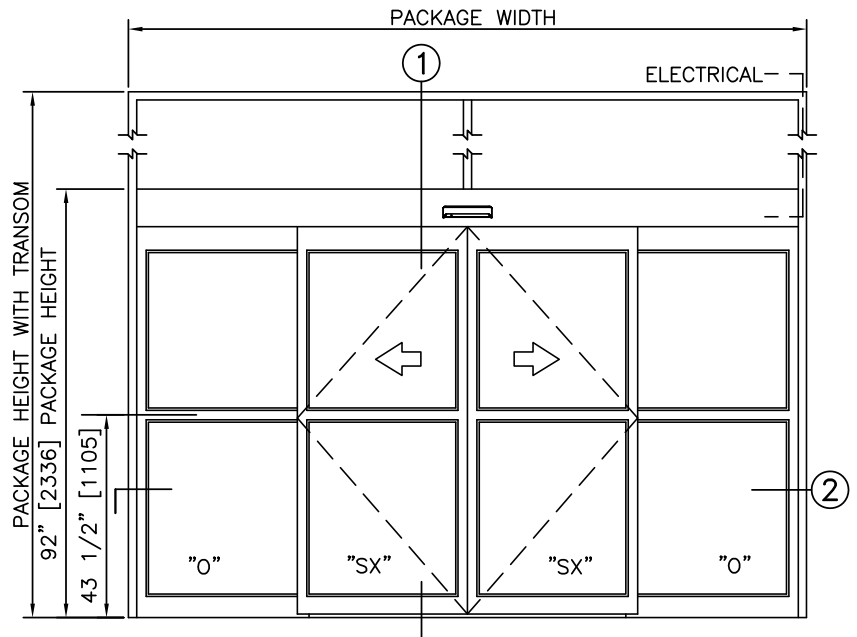

ELEVATION

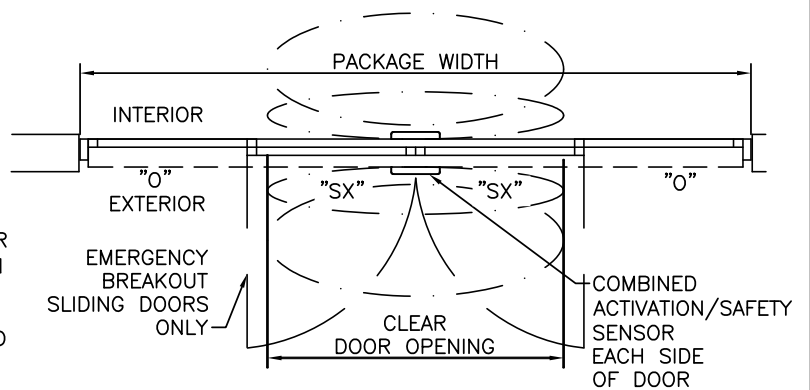

PLAN

NOTES

1. ELECTRICAL REQUIREMENTS: BY ELECTRICAL CONTRACTOR
120 VAC, 5 AMP MIN TO POWER OPERATOR
CONTROL CIRCUIT FROM SECURE ACTIVATION TO OPERATOR
2. ROUGH OPENING SHALL PROVIDE 1/4"[6] SHIM SPACE ON SIDES AND TOP OF PACKAGE.
3. LIMITS OF ACTIVATION AND SAFETY ZONES ARE FOR REFERENCE ONLY; SEE ANSI/BHMA A156.10 FOR DETAILED REQUIREMENTS.
4. SEE SPECIFICATIONS FOR ADDITIONAL INFORMATION.

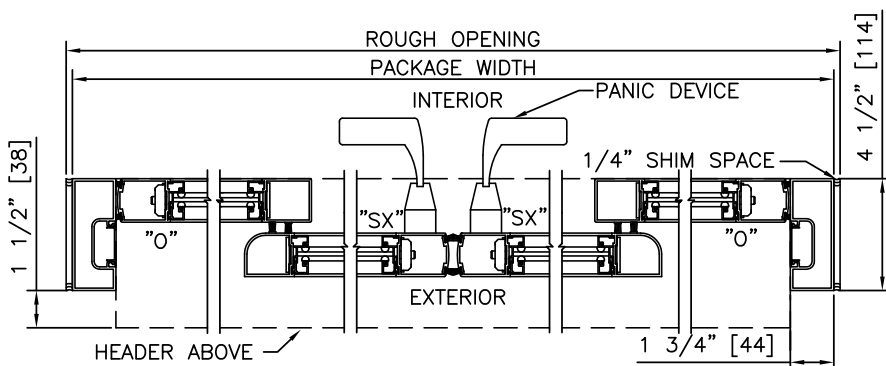

2 HORIZONTAL SECTION

TYPICAL PACKAGE DIMENSIONS (NARROW STILE)

PACKAGE WIDTH	NOMINAL CLEAR DOOR OPENING	DOOR PANEL NOMINAL WIDTH	EMERGENCY BREAKOUT NOM. WIDTH
120"	48.3"	30.3"	55.6"
144"	60.3"	36.3"	67.6"
168"	72.3"	42.3"	79.6"

**DURA-GLIDE
2000
SERIES**

BI-PARTING WITH ACCESS CONTROL, RECESSED

PROJECT INFORMATION

PROJECT NAME:

LOCATION:

DOOR NUMBER(S):

DATE:

SHEET: OF

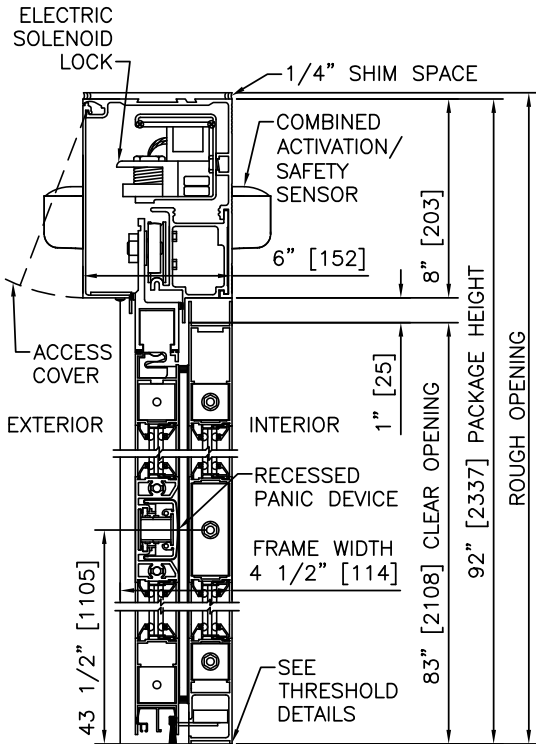

1 VERTICAL SECTION

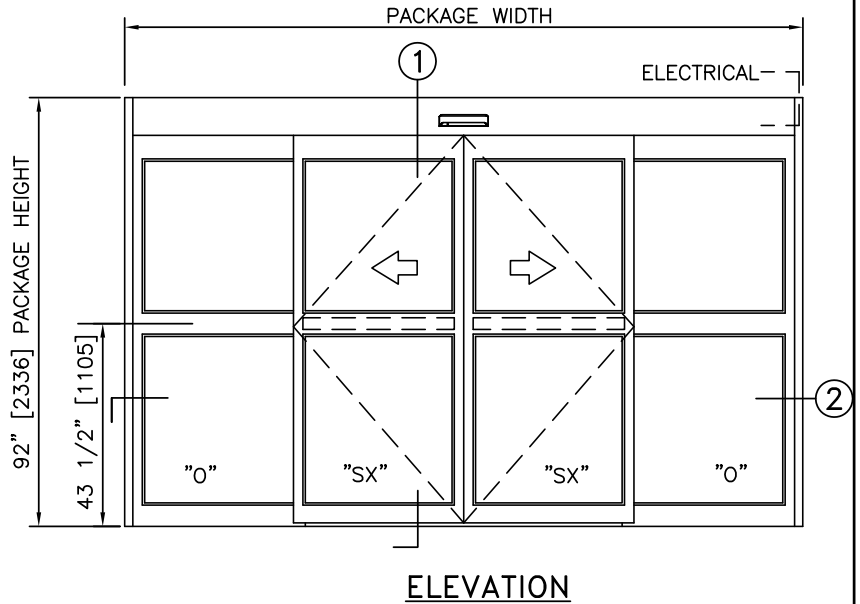

ELEVATION

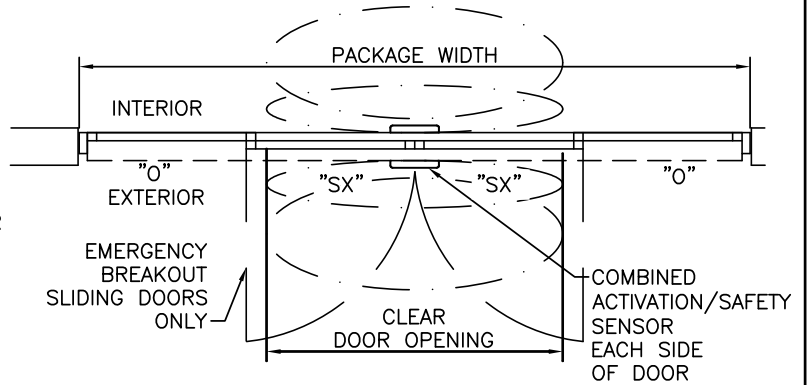

PLAN

NOTES

1. ELECTRICAL REQUIREMENTS: BY ELECTRICAL CONTRACTOR 120 VAC, 5 AMP MIN TO POWER OPERATOR CONTROL CIRCUIT FROM SECURE ACTIVATION TO OPERATOR
2. ROUGH OPENING SHALL PROVIDE 1/4" [6] SHIM SPACE ON SIDES AND TOP OF PACKAGE.
3. LIMITS OF ACTIVATION AND SAFETY ZONES ARE FOR REFERENCE ONLY; SEE ANSI/BHMA A156.10 FOR DETAILED REQUIREMENTS.
4. SEE SPECIFICATIONS FOR ADDITIONAL INFORMATION.

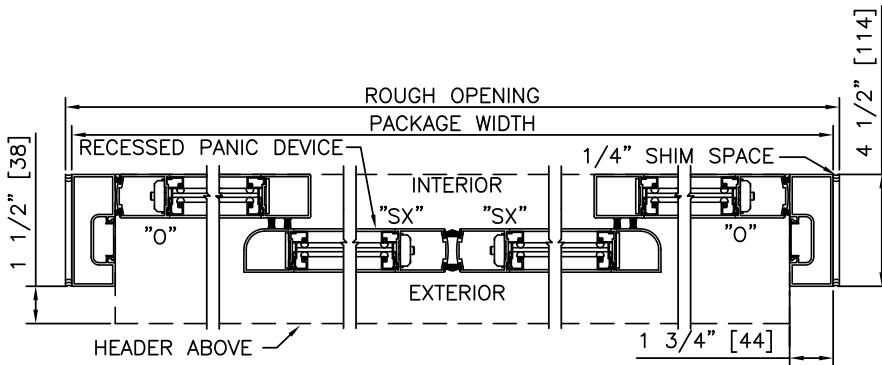

2 HORIZONTAL SECTION

TYPICAL PACKAGE DIMENSIONS (NARROW STILE)

PACKAGE WIDTH	NOMINAL CLEAR DOOR OPENING	DOOR PANEL NOMINAL WIDTH	EMERGENCY BREAKOUT NOM. WIDTH
120"	48.3"	30.3"	55.6"
144"	60.3"	36.3"	67.6"
168"	72.3"	42.3"	79.6"

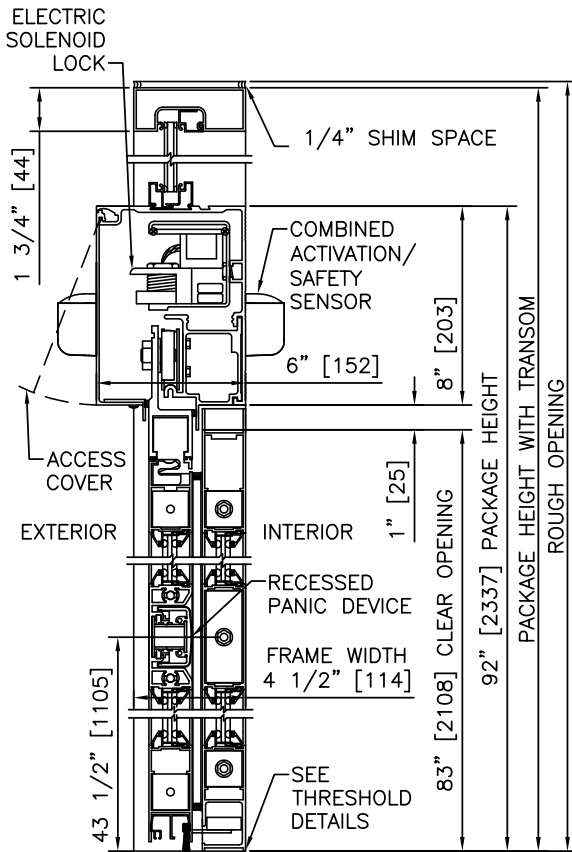

① VERTICAL SECTION

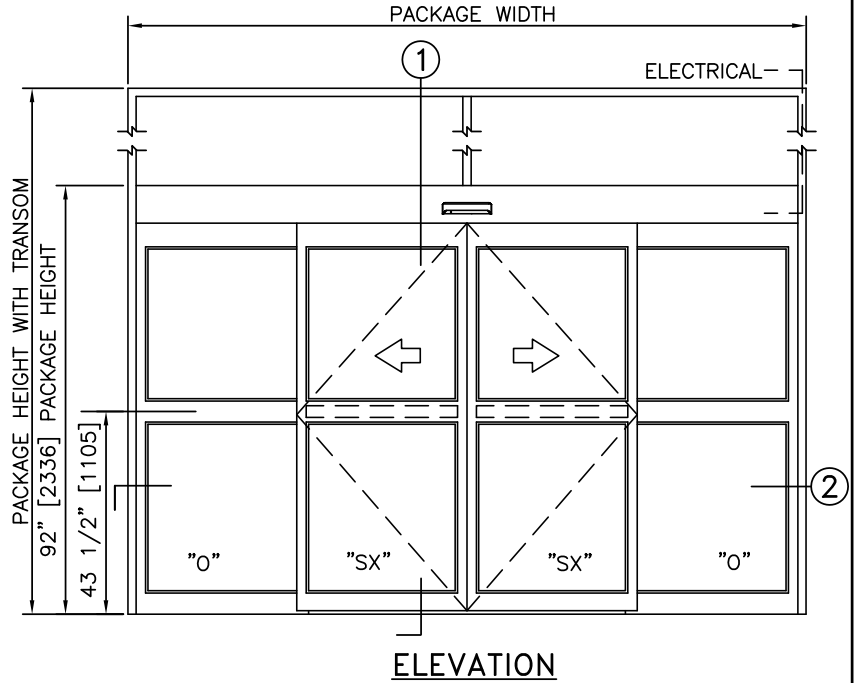

ELEVATION

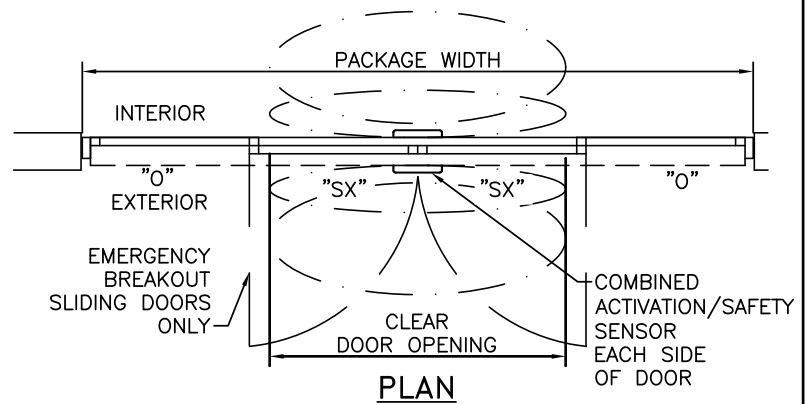

PLAN

NOTES

1. ELECTRICAL REQUIREMENTS: BY ELECTRICAL CONTRACTOR
120 VAC, 5 AMP MIN TO POWER OPERATOR
CONTROL CIRCUIT FROM SECURE ACTIVATION TO OPERATOR
2. ROUGH OPENING SHALL PROVIDE 1/4"[6] SHIM SPACE ON SIDES AND TOP OF PACKAGE.
3. LIMITS OF ACTIVATION AND SAFETY ZONES ARE FOR REFERENCE ONLY; SEE ANSI/BHMA A156.10 FOR DETAILED REQUIREMENTS.
4. SEE SPECIFICATIONS FOR ADDITIONAL INFORMATION.

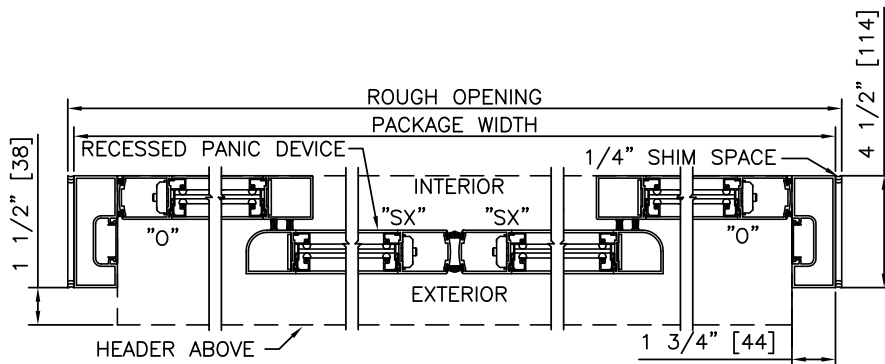

② HORIZONTAL SECTION

TYPICAL PACKAGE DIMENSIONS (NARROW STILE)

PACKAGE WIDTH	NOMINAL CLEAR DOOR OPENING	DOOR PANEL NOMINAL WIDTH	EMERGENCY BREAKOUT NOM. WIDTH
120"	48.3"	30.3"	55.6"
144"	60.3"	36.3"	67.6"
168"	72.3"	42.3"	79.6"

**DURA-GLIDE
2000
SERIES**

BI-PARTING, SURFACE APPLIED

PROJECT INFORMATION

PROJECT NAME:

LOCATION:

DOOR NUMBER(S):

DATE:

SHEET: OF

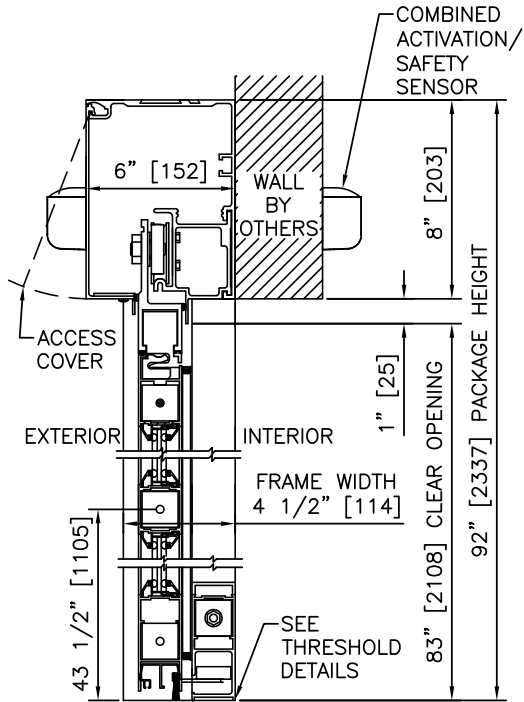

1 VERTICAL SECTION

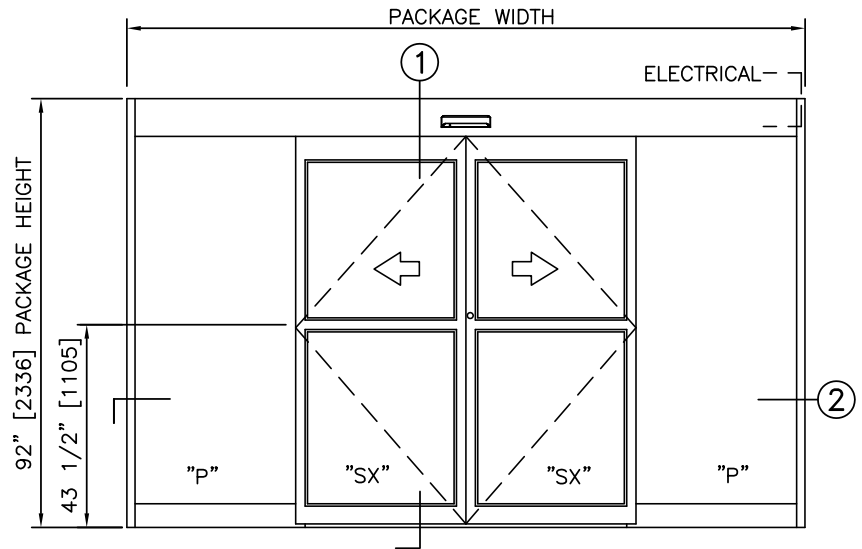

ELEVATION

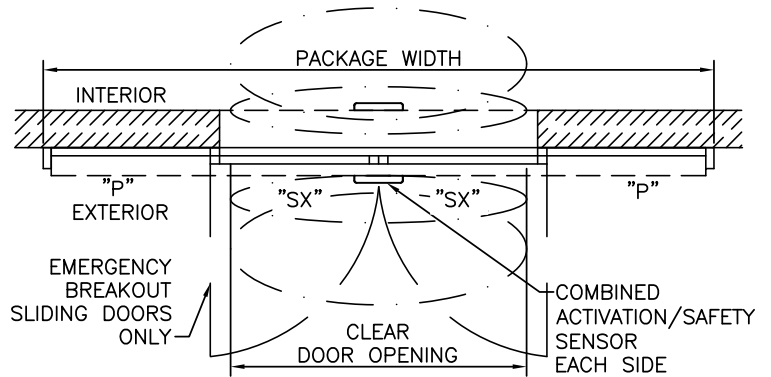

PLAN

NOTES

1. ELECTRICAL REQUIREMENTS: 120 VAC, 5 AMP MIN TO POWER OPERATOR BY ELECTRICAL CONTRACTOR.
2. ACTIVATION AND SAFETY ZONES ARE FOR REFERENCE ONLY; SEE ANSI/BHMA A156.10 FOR DETAILED REQUIREMENTS.
3. SEE SPECIFICATIONS FOR ADDITIONAL INFORMATION.

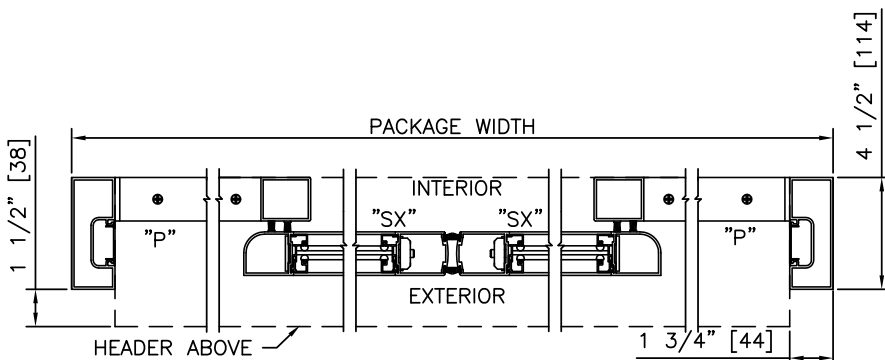

2 HORIZONTAL SECTION

TYPICAL PACKAGE DIMENSIONS (NARROW STILE)

PACKAGE WIDTH	NOMINAL CLEAR DOOR OPENING	DOOR PANEL NOMINAL WIDTH	EMERGENCY BREAKOUT NOM. WIDTH
120"	48.3"	30.3"	55.6"
144"	60.3"	36.3"	67.6"
168"	72.3"	42.3"	79.6"

**DURA-GLIDE
2000
SERIES**

BI-PARTING WITH ACCESS CONTROL, RECESSED, SURFACE APPLIED

PROJECT INFORMATION

PROJECT NAME:

LOCATION:

DOOR NUMBER(S):

DATE:

SHEET: OF

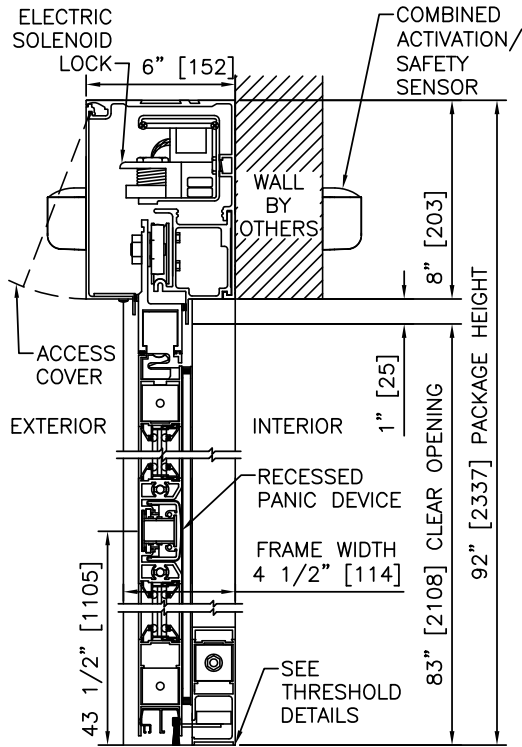

1 VERTICAL SECTION

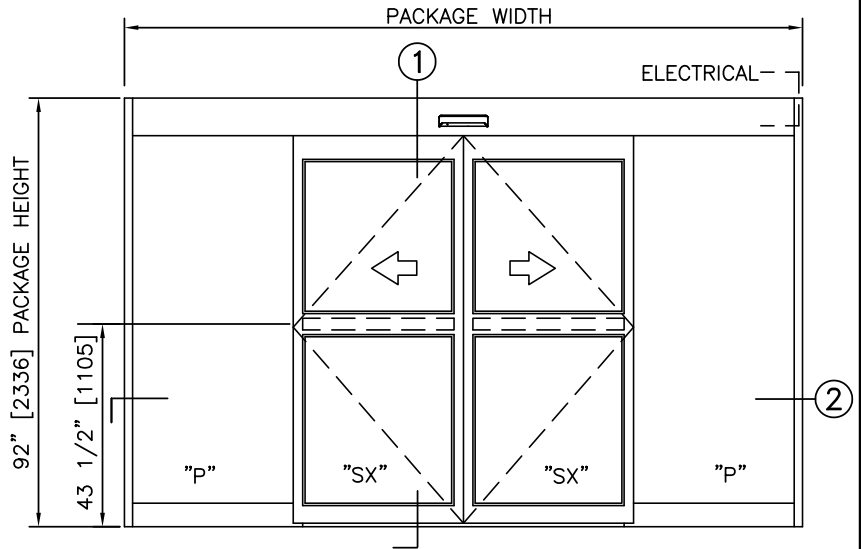

ELEVATION

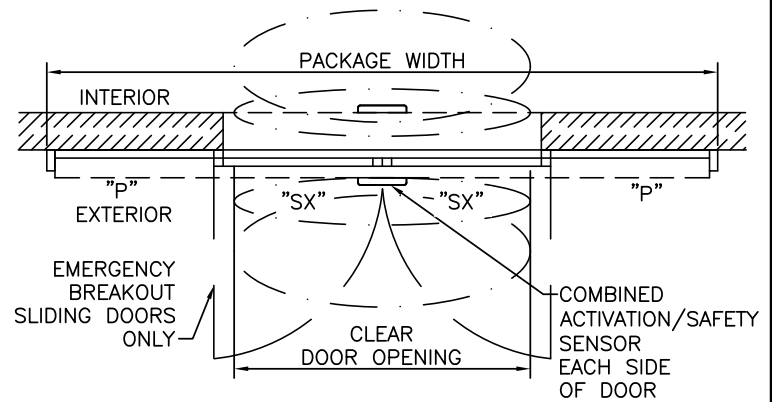

PLAN

NOTES

1. ELECTRICAL REQUIREMENTS: BY ELECTRICAL CONTRACTOR
120 VAC, 5 AMP MIN TO POWER OPERATOR
CONTROL CIRCUIT FROM SECURE ACTIVATION TO OPERATOR
2. LIMITS OF ACTIVATION AND SAFETY ZONES ARE FOR REFERENCE ONLY; SEE ANSI/BHMA A156.10 FOR DETAILED REQUIREMENTS.
3. SEE SPECIFICATIONS FOR ADDITIONAL INFORMATION.

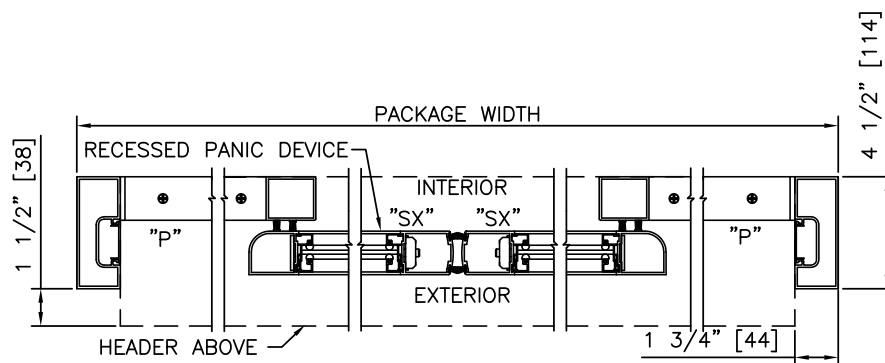

2 HORIZONTAL SECTION

TYPICAL PACKAGE DIMENSIONS (NARROW STILE)

PACKAGE WIDTH	NOMINAL CLEAR DOOR OPENING	DOOR PANEL NOMINAL WIDTH	EMERGENCY BREAKOUT NOM. WIDTH
120"	48.3"	30.3"	55.6"
144"	60.3"	36.3"	67.6"
168"	72.3"	42.3"	79.6"